

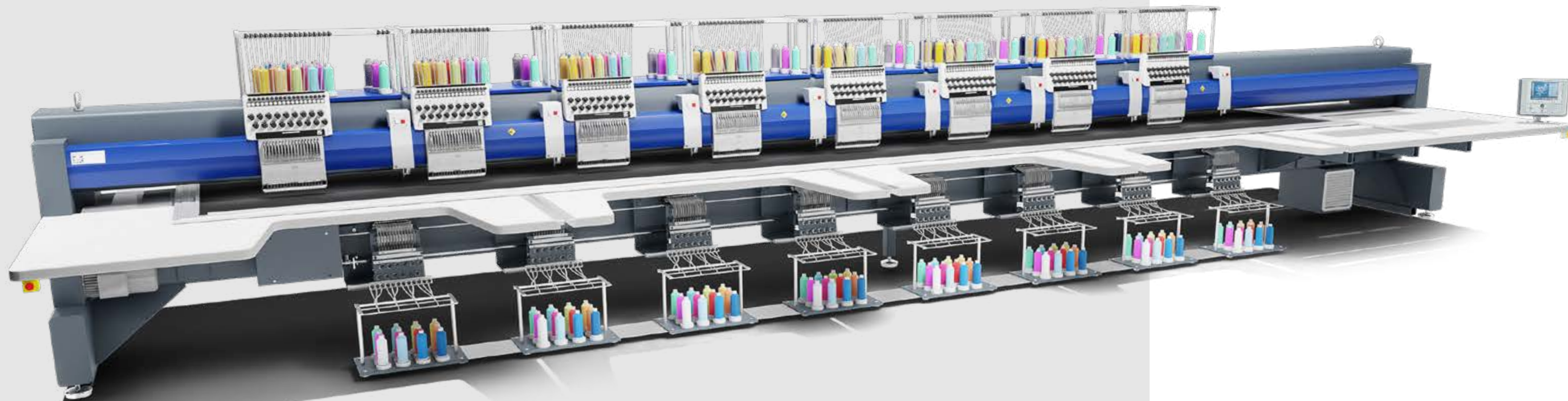

09 | 2022

ZSK technical News and Innovations



CYHH 0818-840 (1200)

- Combination machine with 8 F-Heads and 8 K-Heads
- F-Heads mit 18 colours
- K-Heads with 12 colours
- Head distance 840mm
- Servo Drives
- Fast colour change
- Fast catcher motor

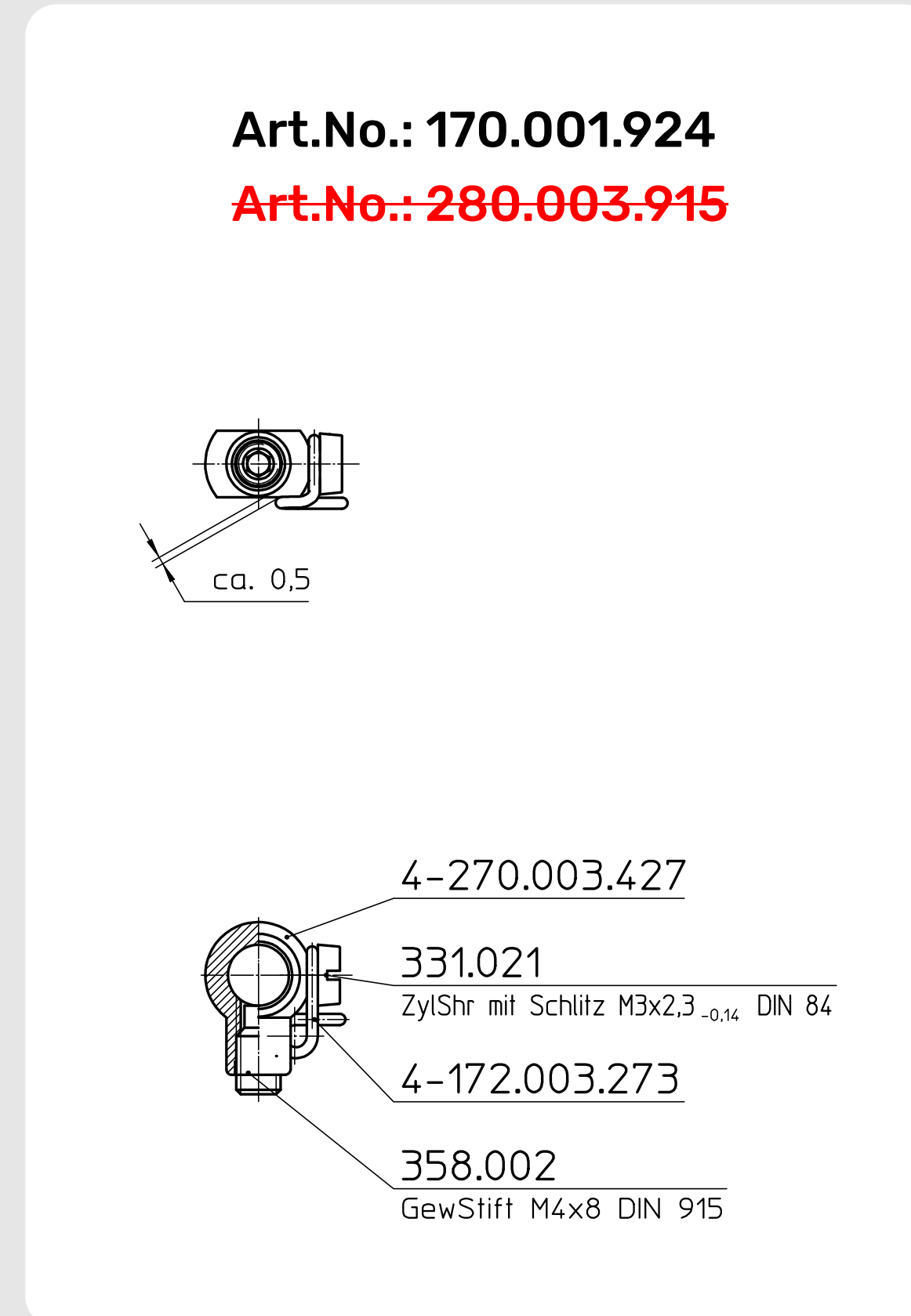
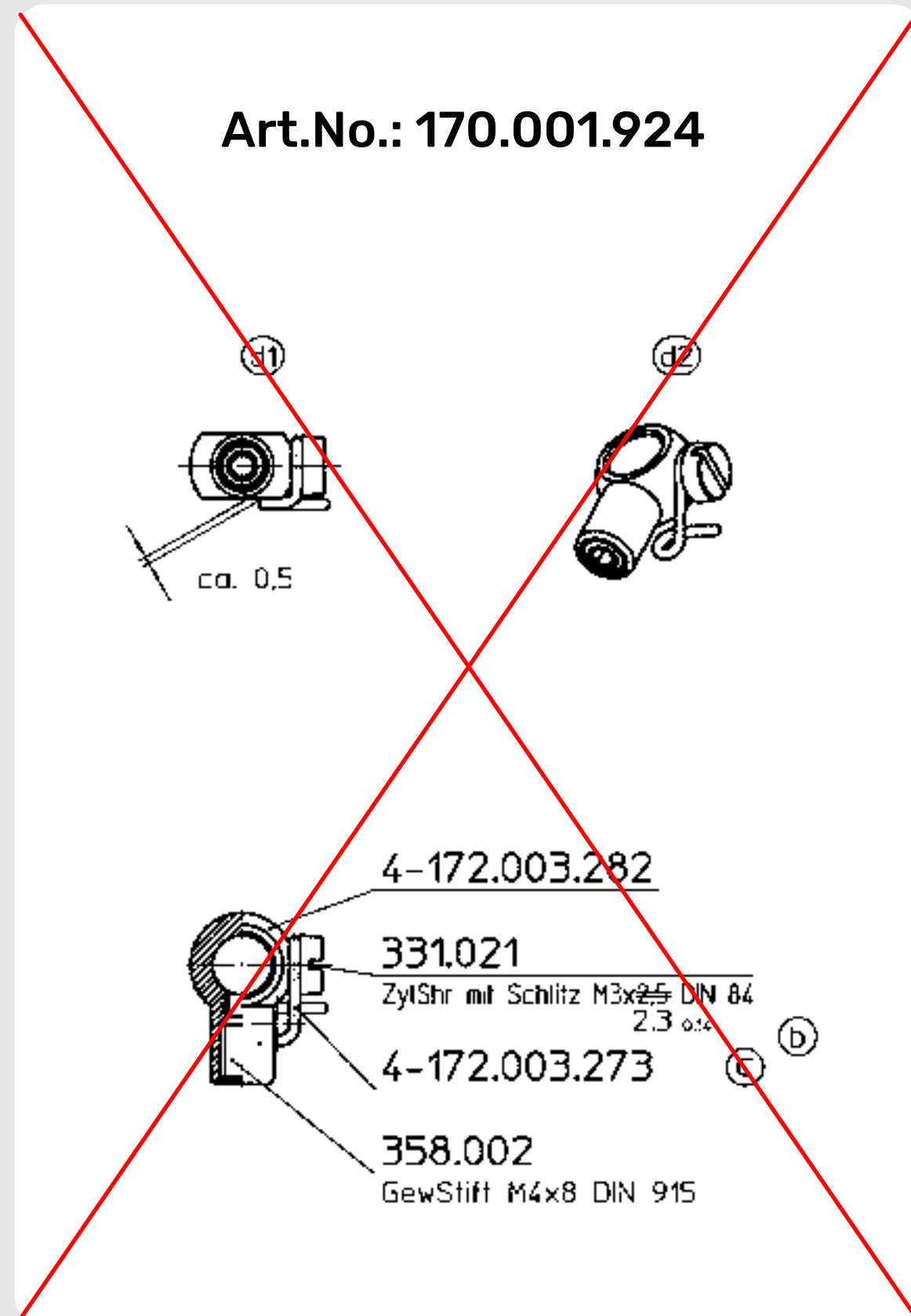

Needle Block

In the future all ZSK machines will be equipped with short needle blocks. This offers the advantage that stitches can be made closer to the frame and the embroidery field can be used more efficiently.

Especially for the automotive sector and in combination with our customized frames, this is a major advantage.



18N thread tension

ZSK will gradually upgrade RACER II and Flatbed models with 18 needles with the new thread tension, which is already known from the Sprint 8.

Technological evolution has led to the modification of the thread tension, which is characterised by a new design and an optimised thread run.



ZSK Stickmaschinen GmbH
Magdeburger Str. 38-40
47800 Krefeld

Fon: +49 (0) 2151 444 0
Fax: +49 (0) 2151 444 170
E-Mail: zsk@zsk.de